

## Energy products

# Gas metering valve C422855

1½-inch flange, 150 to 200 vdc,  
electromechanically actuated (EMA)



Meggitt's 1½-inch globe style gas metering valve is in use on a variety of industrial gas turbine engines. With millions of field operating hours, this design continues to prove the high reliability of Meggitt EMA technology.

### Specifications

<b>Function:</b>	Precision Fuel Gas Metering for aero-derivative turbine engine control
<b>Physical size:</b>	9.88" flange to flange, 23" high
<b>Weight:</b>	75 pounds
<b>Flange type:</b>	1.5" ANSI B16.5 CL 600 raised face flanges
<b>Line pressure:</b>	100 to 1120 psig
<b>Fluid temperature:</b>	0 to 300°F
<b>Ambient temperature:</b>	-40 to 158°F
<b>Performance:</b>	
<b>Flow:</b>	Linear trim, 0 to 4.0 pounds/sec natural gas, Cv = 40
<b>Pressure drop:</b>	25 psid maximum (3.5 pounds/sec, 500 psig)
<b>Leakage:</b>	ANSI class IV
<b>Operating time:</b>	100 msec full stroke response, 300 msec fail-safe closed
<b>Electrical:</b>	
<b>Motor:</b>	Steady state, 75 watts, 150 to 200 VDC, 0.30 amperes; peak (100msec); 1200 watts, 8 amperes maximum
<b>Resolver:</b>	4 VAC, 25 to 60 ma maximum
<b>Position switch:</b>	20 to 32 VDC, SPDT

Actuator also available in 90 to 130 VDC version

### Key features

- Exceptional accuracy, ±1% of flow point
- High speed brushless DC servo motor performance, 20 Hz frequency response
- 100 msec full stroke response time
- Used on both DLE and SAC turbine engines
- Explosion proof design, CSA/UL certified for NEC class 1, division 1, groups C and D, temp code T4, CE zone 1, EExd IIB, CE-ATEX and PED certified
- All stainless steel valve and yoke materials for NACE compliance
- No maintenance required under normal conditions

## Meggitt Control Systems

### Our product competencies & services:

Aerospace valves | Thermal management solutions | Environmental control systems | Electro-mechanical products  
Ground fueling products | **Energy products** | Aftermarket services

**MEGGITT**  
smart engineering for  
extreme environments

Energy products

# Gas metering valve C422855

## Key dimensions

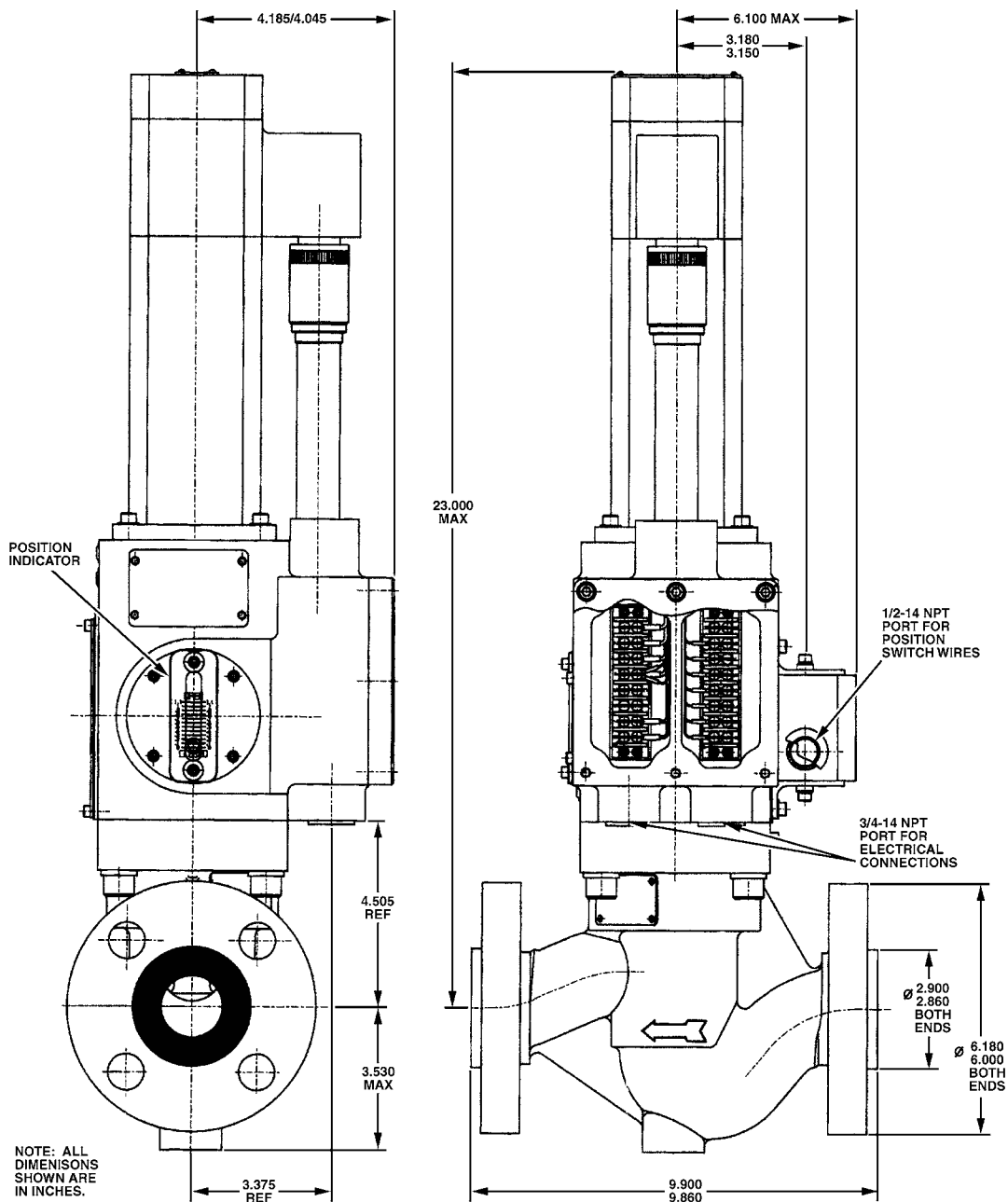

## Contact

### Meggitt Controls

12838 Saticoy St  
North Hollywood  
California 91605-3505  
USA

Telephone: (818) 765-8160  
FAX: (818) 759-2194

[www.meggitt.com](http://www.meggitt.com)

## Meggitt Control Systems

Our product competencies & services:  
Aerospace valves | Thermal management solutions | Environmental control systems | Electro-mechanical products  
Ground fueling products | **Energy products** | Aftermarket services

**MEGGITT**  
smart engineering for  
extreme environments